

Double Wall Hoses

Amniflex double wall hoses are specifically designed for heating or cooling media during transport through the inner hose. Typically, the inner hose is used for the conveyance of the operating medium (product) and the outer hose, with separate connections, for the transport of, for example, steam, hot water, thermal oil or a coolant.

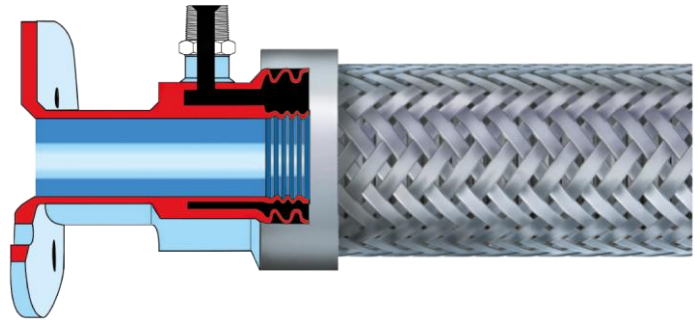

The maximum operating temperature for Amniflex double wall hoses is 600 °C, depending on the method of assembling, choice of materials and the product in both hoses. Double wall hoses are suitable as a transport hose in order to eliminate misalignment of piping and for the absorbing of movements in pipe systems.

Double wall hoses consist of two stainless steel hoses which are placed over each other. Depending on pressure and temperature, the hoses are fitted with one or more stainless steel braids. The quality of the stainless steel hoses are always in accordance with the specific situation of the application. Also the connecting parts on both, the inner and the outer hose, are welded according to customer specifications.

Amniflex double wall hoses are available in any length. If the hose has to absorb movements, in the piping, the formulas for calculating the hose length must be strictly adhered to, in which case the specifications of the hose with the largest diameter (outside hose) should be used.

Amniflex Double Wall Hoses can be equipped with:

- Asbestos-free thermal insulation.
- Cover over the hose to protect against dirt, etc.
- Stainless steel anti-kink spiral on one or both ends of the hose.
- Stainless steel protection spiral along the entire length of the braid against damage.
- Special handles to prevent burns or frostbite.
- PTFE lining for pharmaceutical and food applications.

Data Table			
Inner hose DN		Outer hose DN	
mm (in.)	mm (in.)	mm (in.)	mm (in.)
1"	Ø 25	2"	Ø 50
1½"	Ø 40	2½"	Ø 65
2"	Ø 50	4"	Ø 100
3"	Ø 80	5"	Ø 125
4"	Ø 100	6"	Ø 150

Technical Description:

- 1. Inner Hose
- 2. Inner Braiding
- 3. Outer Hose
- 4. Outer Braiding
- 5. Nipple (2x)
- 6. Cover (Optional)

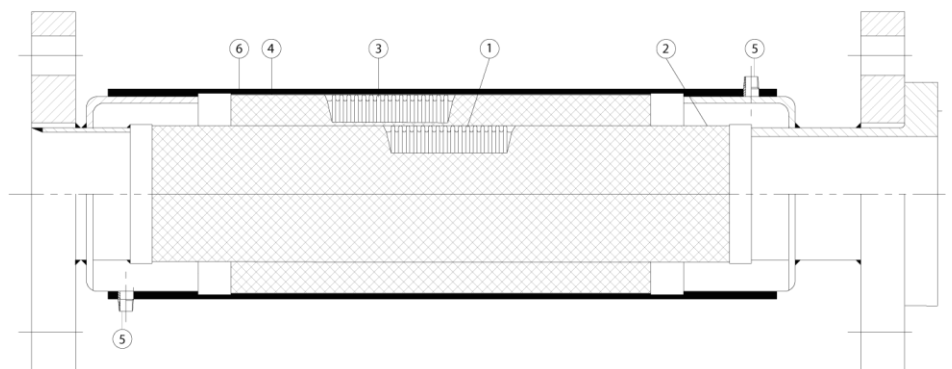

information in this document is without any obligation, specifications subject to change without any notice

Amniflex B.V.

Abraham van Stolkweg 118
3041 JA, Rotterdam
T: +31(0)10 2982121
E: amniflex@plastiflex.com
www.amniflex.com

BTW nr. NL862140729B01
Bank: KBC Bank NV
KREDNL2XXXX
IBAN NL23 KRED0633024376

K.v.K. Rotterdam nr. 81568053

Al onze aanbiedingen en leveranties geschieden volgens onze algemene leveringsvoorwaarden.

