

GUIDE TO THE USE OF AMNITEC METAL BELLOWS AND EXPANSION JOINTS

INTRODUCTION

When a length of steel pipe, fixed at both ends, is heated uniformly through 100 C° a stress of approximately 15 tons per square inch is generated by the natural desire of the pipe to expand. In practice, this means that as a result of this thermal expansion, either one of the fixed ends becomes "unfixed" or the pipe buckles to accommodate the resultant expansion and thus relieve the stress. Either of these situations is totally unacceptable in actual pipe work systems. Fortunately, engineers have devised "spring tubes" in the form of metal or rubber bellows which are capable of remaining pressure tight whilst they are compressed (or extended) axially, or, while one end moves laterally or angularly in relation to the other. Amnitec bellows have been the heart of pipe work expansion joints for many years and are capable of operating under exactly the same conditions as the pipe work. Continuous active development has meant that today the most advanced technology allied to proven experience is available to solve all modern pipe line expansion problems.

This guide outlines the basic principles governing the application of Amnitec metal and rubber expansion joints to the majority of pipe work situations. If your problem is particularly complicated or if you have any doubts or queries, experienced sales engineers are available to give assistance by phone and/or at site.

NATURAL FLEXIBILITY

Expansion joints need only be used generally where the expansion of the pipe work cannot be accommodated by the natural flexibility of the pipe. This is sometimes referred to as "springing the pipe" and is the cheapest method of accommodating expansion. Pipe is naturally flexible and by using its stress capabilities given the circumstances there could be no need of expansion joints.

GENERAL INFORMATION

A metal expansion joint is a highly engineered product and its design requires a series of technical calculations to ensure that the resulting expansion joint is the one most suited to the purpose and application. To guarantee the accuracy of these calculations calculation software has been developed and integrated into an overall management system that not only optimizes design calculations, but also simultaneously provides quotations and manufacturing specifications, sometimes drawings. The design calculations are based on the latest edition of EJMA recommendations and EN 13445. QA procedures are based on ISO 9001 and EN 729.

DEFINITION OF METAL EXPANSION JOINTS

The term metal expansion joint is used to describe any device containing one or more metal bellows that are used to absorb dimensional changes such as those caused by thermal expansion or contraction in pipelines, ducting or vessels and their components.

HIGH ENGINEERED PRODUCTS

Metal expansion joints are used in piping systems to absorb different thermal expansion while containing the system pressure. Typical, but not limiting, service conditions cover pressures ranging from full vacuum to high pressures and temperatures from cryogenic to plus 1100 C°. Such expansion joints may be described as high engineered products. The system operating characteristics, the expansion joint design, material and manufacturing quality, and the installation, test and operating procedures, must all be considered carefully before any expansion joint is installed.

Amniflex B.V.

Abraham van Stolkweg 118
3041 JA, Rotterdam
T: +31(0)10 2982121
E: amniflex@plastiflex.com
www.amniflex.com

BTW nr. NL862140729B01
Bank: KBC Bank NV
KREDNL2XXXX
IBAN NL23 KRED0633024376

K.v.K. Rotterdam nr. 81568053

Al onze aanbiedingen en leveranties geschieden volgens onze algemene leveringsvoorwaarden.



Instead of most commonly used piping components, a bellow is constructed of relatively thin walled material in order to provide the flexibility needed to absorb the mechanical and thermal movements expected during service. This requires design, manufacturing quality, handling, installation and inspection procedures which reflect the unique nature of the product.

In general, the most reliable and safe metal expansion joint installations can be assured only after close co-operation, communication and understanding between the user and manufacturer. Metal expansion joints are able to compensate for the following movements

- Axial +/- movements
- Lateral +/- movements
- Angular movement (1 and 2 planes)

and combinations of the movement, which may be caused by:

- thermal expansion
- pressure, pressure pulsation and pressure thrust
- vibration
- misalignments
- foundation settlement (tank storage)
- assembly movement
- relative movements between other elements

that are typical of piping and ducting systems which feature prominently in:

- the processing industry
- chemical and petro-chemical industry
- cement works
- steel works
- pulp and paper industry
- energy sector such as power generation, gas turbines and heating systems.

Metal expansion joints - the best choice for piping - when a solution is required for:

- vacuum proof
- pressure proof
- temperature proof
- corrosion proof
- reliable and safe
- durable, with long service life
- maintenance free
- an optimum balance between flexibility and pressure

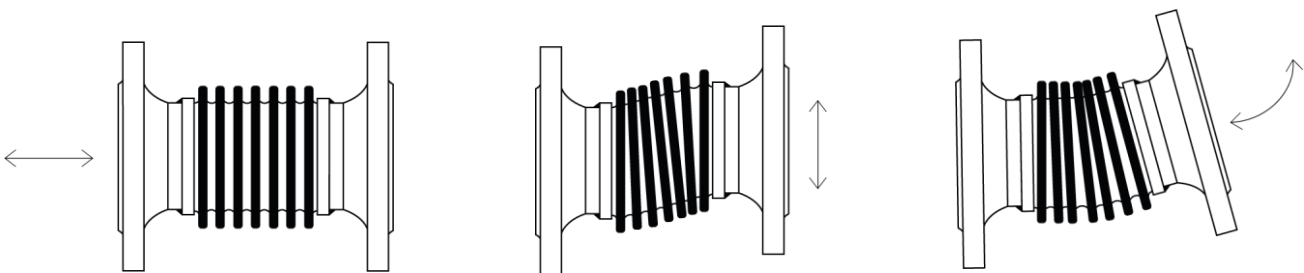

Amniflex B.V.

Abraham van Stolkweg 118
3041 JA, Rotterdam
T: +31(0)10 2982121
E: amniflex@plastiflex.com
www.amniflex.com

BTW nr. NL862140729B01
Bank: KBC Bank NV
KREDNL2XXXX
IBAN NL23 KRED0633024376

K.v.K. Rotterdam nr. 81568053

Al onze aanbiedingen en leveranties geschieden volgens onze algemene leveringsvoorwaarden.



EXPANSION JOINTS

If natural flexibility cannot accommodate the expansion, then expansion joints must be used. Before proceeding with the task of selecting and positioning the type of expansion joint:

- A) Determine**
 - 1 Pipe nominal size
 - 2 Medium
 - 3 Flow velocity
 - 4 Flow direction
 - 5 Design pressure
 - 6 Test pressure
 - 7 Maximum and minimum temperatures
 - 8 Bellows material
 - 9 Pipe specification and material
 - 10 Flange specification and material
 - 11 Also consult, check and fill in the AmniTec questionnaire on our website
- B) Find out the (thermal) expansion for each straight pipe section.**
- C) Note the position of any pre-determined fixed points and positions where loadings on equipment or structures would be critical or acceptable**
(Also see anchors or fixed points).
- D) Decide or ask whether internal sleeves or external covers are required to minimize contact between the internal surface of the bellows and the medium flowing or to provide external protection.**
- E) Select and specify the type of AmniTec expansion joint you require and always take the opportunity to check your selection with our experienced sales team.**

ANCHORS OR FIXED POINTS

The pipeline in which the expansion joint is installed, must be fixed by fixed point/anchors which are strong enough to absorb the reaction forces produced by, but not restricted to:

- the inside pressure, operating or test-pressure. (pressure thrust)
- the inherent resistance of the expansion joint. (spring rate N/mm)

OPERATING CONDITIONS AND CRITICAL PARAMETERS

Temperature

In situations where the ambient temperature is expected to vary significantly during pipe line construction, special care in expansion joint installation may be necessary. The maximum and minimum design, operating and installation temperatures should be accurately stated.

Pressure

The design pressure, operating pressure and test pressure in the system should be specified realistically without the addition of arbitrary safety factors, as this practice necessitates greater bellows material thickness to withstand the overstated pressures. This, however, may have an adverse effect on the fatigue life of the bellow.

Amniflex B.V.

Abraham van Stolkweg 118
3041 JA, Rotterdam
T: +31(0)10 2982121
E: amniflex@plastiflex.com
www.amniflex.com

BTW nr. NL862140729B01
Bank: KBC Bank NV
KREDNL2XXXX
IBAN NL23 KRED0633024376

K.v.K. Rotterdam nr. 81568053

Al onze aanbiedingen en leveranties geschieden volgens onze algemene leveringsvoorwaarden.



Medium, flow and sleeve (liner)

The bellow material specified must be compatible, not only with the flowing medium, but also with any water treatment or pipeline cleaning chemicals that may be used and with the external environment at the operating temperature.

If the flowing medium is a:

- powder that can compact
- liquid
- slurry that may solidify
- deposit solid particles in the line

then provision should be made to prevent entrapment or solidification in the convolutions which could result in serious damage to the expansion joint or pipeline. Internal sleeves are usually installed in the direction of flow. It is obviously undesirable that any of the fluid material should be trapped behind the sleeve. To avoid this we recommend that drain holes, drilled into either the sleeve or the purge connection should be specified. Where backflow will be encountered, an extra heavy sleeve can be specified to prevent buckling of the sleeve and to obviate possible damage to the bellow. In applications where the gas or the fluid is running at a high velocity, the use of a sleeve is recommended.

TYPE OF EXPANSION JOINTS, DISTRIBUTION OF MOVEMENTS

All expansion joints can be classified as either AXIAL, LATERAL and/or ANGULAR according to the type of movements that takes place in the bellows, or combination of those.

Absorption of axial movement

Axial joints are mounted in the pipe line to absorb movement along the axis of the pipe. Axial movement may be referred to as compression, the decrease in length or elongation/extension, the increase in length of an expansion joint along its longitudinal axis. They are the commonest and the simplest but rely completely on the pipe work for guidance and restraint. They can have sleeves or covers which will help to reduce internal turbulence or to afford external protection. They can also, if required, be fitted with restraining tie bars as an added precaution against anchor or guide failure.

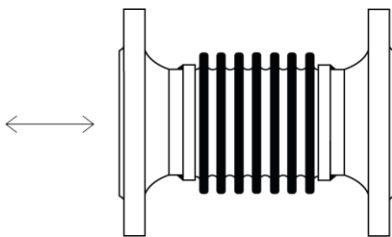

Amniflex B.V.

Abraham van Stolkweg 118
3041 JA, Rotterdam
T: +31(0)10 2982121
E: amniflex@plastiflex.com
www.amniflex.com

BTW nr. NL862140729B01
Bank: KBC Bank NV
KREDNL2XXXX
IBAN NL23 KRED0633024376

K.v.K. Rotterdam nr. 81568053

Al onze aanbiedingen en leveranties geschieden volgens onze algemene leveringsvoorwaarden.



Absorption of lateral movement

Lateral movement may be referred to as lateral offset or deflection (+/-)*, the relative displacement of the two ends of an expansion joint perpendicular to its longitudinal axis. In reality, lateral deflection is a special case of angular rotation. Each end of the bellow (or bellows in a universal joint) of a single type expansion joint, rotate in opposite directions to produce the total lateral deflection. Lateral deflection results in unequal distribution of movement over the bellows, the amount of displacement increasing with the distance from the centre of the expansion joint.

* not circa, plus and/or minus

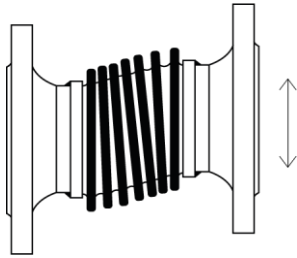

Absorption of angular movement/rotation

Angular movement may be referred to as angular rotation or rotational movement, the displacement of the longitudinal axis of the expansion joint from its initial straight line position into a circular arc. The expansion joint bellows absorb pure angular rotation by extending uniformly on one side and compressing uniformly on the other. Angular movement initiates a column squirm. Compensation is made for this in the design calculation.

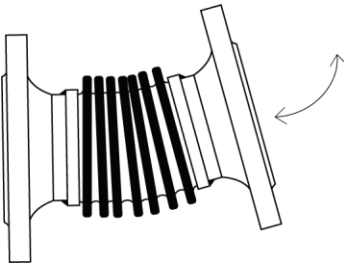

MOVEMENTS IN COMBINATION

Combining movements to be absorbed in an expansion joint may be expressed as axial compression (x), lateral deflection (y) and angular rotation (>) occurring in the same plane. The specified axial and lateral values are all maximum values at 20 C°, **not combined**, calculated for a minimum of 1000 full cycles. It is possible to check the ability of an expansion joint to take up movements in more than one direction by using various expansion joint combinations.

This is best explained in an **axis diagram**, where the maximum axial and lateral movements are indicated. When combining the movements within the diagram, the required main movement (axial or lateral) will set a limit to the maximum allowable secondary movement. By keeping within the allowed combinations, the functionality and service life of an expansion joint may be executed to its full potential. The individual life time value (max. cycles) for an expansion joint may be read from the diagram directly as an example, always consult AmniTec for guaranteed figures.

Amniflex B.V.

Abraham van Stolkweg 118
3041 JA, Rotterdam
T: +31(0)10 2982121
E: amniflex@plastiflex.com
www.amniflex.com

BTW nr. NL862140729B01
Bank: KBC Bank NV
KREDNL2XXXX
IBAN NL23 KRED0633024376

K.v.K. Rotterdam nr. 81568053

Al onze aanbiedingen en leveranties geschieden volgens onze algemene leveringsvoorwaarden.



Diagram

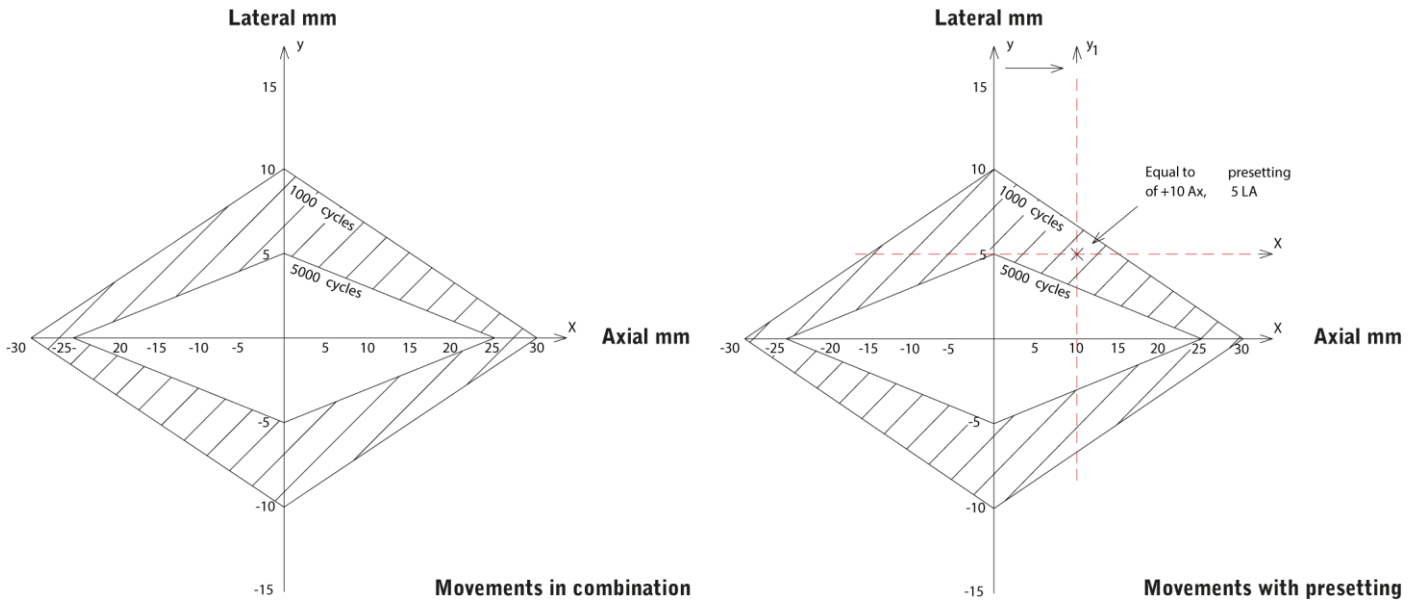

PRE-SETTING AN EXPANSION JOINT

Example of pre-setting

The movement diagram also defines in which area the expansion joint can operate. If the operating point lies outside the defined movement area and if the expansion joint is installed in its normal length at delivery (neutral length), it may be pre-set during installation. This will move the operating point inside the allowed movement area. Full movement potential of the expansion joint and the consequent extension of its lifetime can be achieved by pre-setting the expansion joint even further in the axial direction.

By pre-setting expansion joints laterally at the same time, the optimum operating conditions for the expansion joint are achieved and thereby the longest life.

Natural

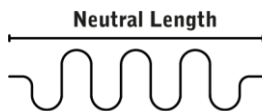

Pre - set

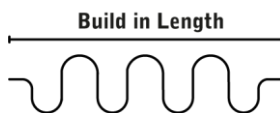

Amniflex B.V.

Abraham van Stolkweg 118
3041 JA, Rotterdam
T: +31(0)10 2982121
E: amniflex@plastiflex.com
www.amniflex.com

BTW nr. NL862140729B01
Bank: KBC Bank NV
KREDNL2XXXX
IBAN NL23 KRED0633024376

K.v.K. Rotterdam nr. 81568053

Al onze aanbiedingen en leveranties geschieden volgens onze algemene leveringsvoorwaarden.



TYPES OF EXPANSION JOINTS

Choosing a type of an expansion joint always starts with a lot of questions, e.g.

- where in the piping is an expansion joint wanted and/or necessary
- what kind of connections are preferred and/or necessary
- is a liner or inner sleeve recommended
- what about the product (medium)
- what about pressure(`s) and temperature(`s)
- what is the required capability for axial, lateral and angular movement(`s)
- also see our questionnaire on www.amniflex.com

Because of our broad program of metal and rubber joints the selection of a certain joint may be feel complicated and therefore we want to encourage you to contact AmniTec and/ or consult www.amnitec.nl

EXAMPLE'S OF AXIAL JOINTS

Axial expansion joint types of Amniflex are available, but not restricted to, in type's AX1S, with welding ends, AX1F with plate flanges and AX1H with welding neck flanges. Our standard axial expansion joints are to be installed with only one expansion joint between two fixed points. (anchors) Pipeline systems where axial expansion joints are used must be protected against sideways bending by guides, also see our installation instructions.

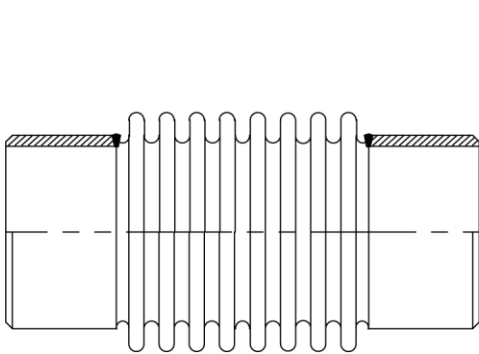

AX1S

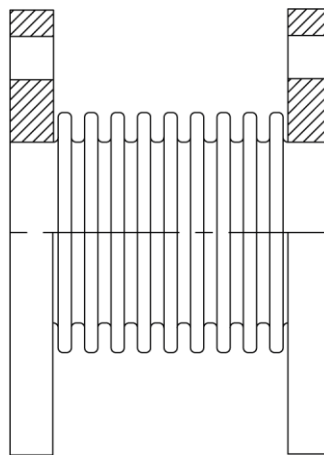

AX1F

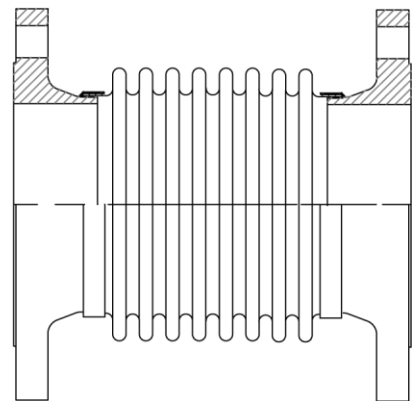

AX1H

Amniflex B.V.

Abraham van Stolkweg 118
3041 JA, Rotterdam
T: +31(0)10 2982121
E: amniflex@plastiflex.com
www.amniflex.com

BTW nr. NL862140729B01
Bank: KBC Bank NV
KREDNL2XXXX
IBAN NL23 KRED0633024376

K.v.K. Rotterdam nr. 81568053

Al onze aanbiedingen en leveranties geschieden volgens onze algemene leveringsvoorwaarden.



EXAMPLE'S OF LATERAL JOINTS

Lateral expansion joint types of Amniflex are available, but not restricted to, in various designs: type's LA1 and LA2 have tie rods allowing lateral movement between bolt and flange. The number of tie rods is depending on the diameter and pressure. The standard lateral expansion joints with tie rods are available in a design with minimal two tie rods. No axial movements are allowed in the system. Type's LA3 and LA4 have flat iron hinges which are fitted through the flanges and welded on the outside. A hinge, which allows lateral movement, is mounted on the fitting above the centre line of the bellows. The standard lateral expansion joints with hinges are available in a design with double bellows. Common to both models is the fact that tie rods and hinges alike have the task of absorbing the loads arising from the operating (test) pressure. Hinges prevent axial expansions.

This means that a lateral expansion joint can only move sideways (laterally) in one or more planes, making it possible for those movements which are perpendicular to the longitudinal direction to be absorbed. Lateral expansion joints are therefore ideal for installation in pipe systems with bends.

The lateral expansion joints are available with flanges or welding ends and in PN6, PN10, PN16 and PN25.

Guides must ensure that the pipeline is only moving in the predetermined direction. When fixed points and guides are mounted, the pipeline can be pressure tested as specified in the documentation. LA1, LA2, LA3, LA4

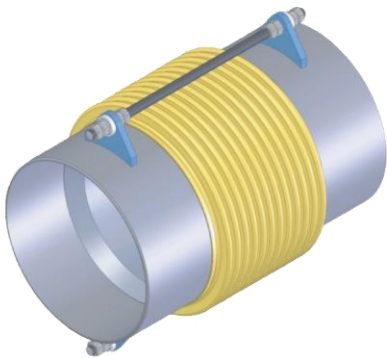

LA1

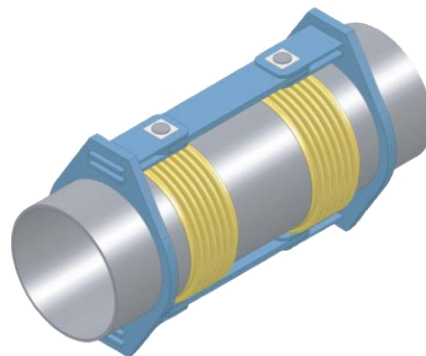

LA3

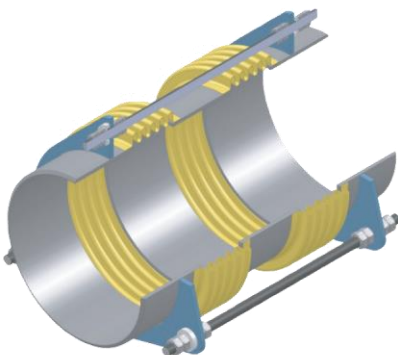

LA2

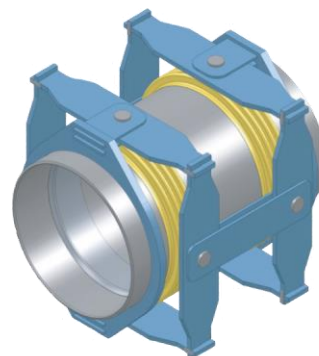

LA4

Amniflex B.V.

Abraham van Stolkweg 118
3041 JA, Rotterdam
T: +31(0)10 2982121
E: amniflex@plastiflex.com
www.amniflex.com

BTW nr. NL862140729B01
Bank: KBC Bank NV
KREDNL2XXXX
IBAN NL23 KRED0633024376

K.v.K. Rotterdam nr. 81568053

Al onze aanbiedingen en leveranties geschieden volgens onze algemene leveringsvoorwaarden.



EXAMPLE'S OF ANGULAR JOINTS

Angular expansion joints are available, but not restricted to, two designs. Type AN1 is designed with flat iron fittings which are fitted through the flanges and welded on the outside. A cylindrical bolt, which allows angular movement in one plane, is mounted on the fitting above the centre line of the bellows. The expansion joint is made with one bellow.

Type AN2 is fitted with flat iron fittings. The fittings are secured to a middle ring with cylindrical bolts, which allow angular movement in all planes, above the centre line of the bellow. The expansion joint is made with one bellow. Common to both type's is the fact that the fittings have the task of absorbing the loads arising from the operating (test) pressure. The fittings make axial expansions impossible, which means that the expansion joint can only absorb bending forces.

Angular expansion joints are suitable for installations where it is not possible to create sturdy fixing points and in pipe systems where bending occurs. Since the angular expansion joints can only absorb bending at least two or three angular expansion joints are required every time to ensure correct absorption of the movement. Two angular expansion joints correspond functionally to one lateral expansion joint, for which reason angular expansion joints are often used in pairs.

Angular expansion joints

- designed to absorb angular movements in all planes
- the hinges are designed to absorb the reaction forces from the internal pressure which means that fixed points are not necessary
- can be designed to withstand the deadweight of the pipe system
- are not to be exposed to torsion
- are available with flanges or welding ends
- design pressure: PN6, PN10, PN16 and PN25

Guides must ensure that the pipeline is only moving in the predetermined direction.

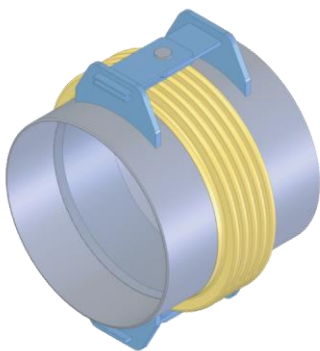

AN1

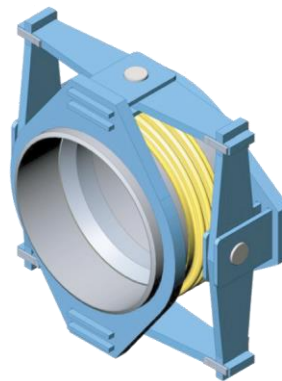

AN2

Amniflex B.V.

Abraham van Stolkweg 118
3041 JA, Rotterdam
T: +31(0)10 2982121
E: amniflex@plastiflex.com
www.amniflex.com

BTW nr. NL862140729B01
Bank: KBC Bank NV
KREDNL2XXXX
IBAN NL23 KRED0633024376

K.v.K. Rotterdam nr. 81568053

Al onze aanbiedingen en leveranties geschieden volgens onze algemene leveringsvoorwaarden.



UNIVERSAL EXPANSION JOINT:

A universal expansion joint consists of two bellows joined by a common connector, a configuration that will absorb any combination of three basic movements: axial, lateral and angular.

Universal expansion joints are normally provided with tie or control rods (a tied universal expansion joint) to distribute the movement between the two bellows of the expansion joint.

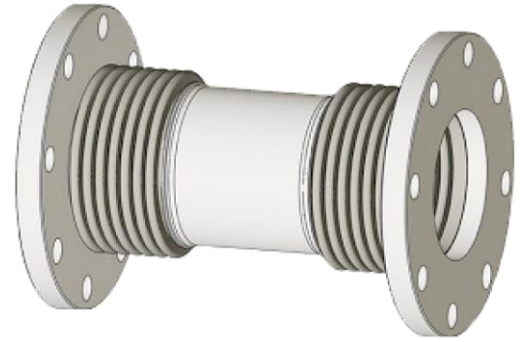

HINGED EXPANSION JOINT

Typically, a hinged expansion joint consists of either one or two bellows in a double hinge design, and, by the use of a pair of pins through the hinge plates attached to the expansion joint ends, it will permit angular rotation in only one plane. The hinges and hinge pins must be designed to restrain the thrust of the expansion joint in response to internal pressure and extraneous forces, where they are present. Hinged expansion joints are often used in sets of two or three in order to function properly.

Where the flexibility of the piping in a single plane system is not sufficient to absorb the thermal expansion of the spool, a system of three, hinged expansion joints may be used.

In this system, the combination of expansion joints absorbs all the thermal expansion of the piping, thus preventing its deflection.

This system produces the lowest forces possible on the intermediate anchors and guides.

The amount of lateral movement that can be absorbed by a system containing a set of hinged expansion joints depends on the distance between the hinge pins. This distance should therefore be as large as possible, in order to exploit the hinge system to its best advantage. If the thermal movements of a piping system occur in only one plane, the use of hinged expansion joints will provide the most efficient method of absorbing them.

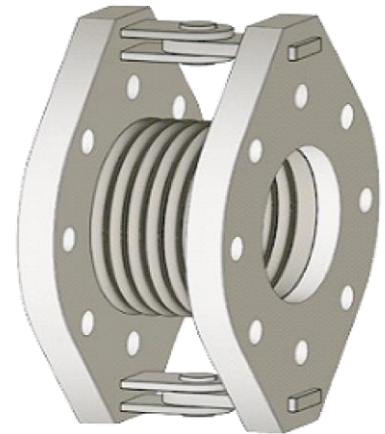

GIMBAL EXPANSION JOINT

Gimbal expansion joints are designed to permit angular rotation in any plane by the use of two pairs of hinges attached to a common floating gimbal ring. The gimbal ring, hinges and pins must be designed to restrain the thrust of the expansion joint due to internal pressure and extraneous forces, when they are present. This type of construction ensures close control of the movement imposed on the bellow. In case of external loadings such as wind, shear and dead weight loads shall be transmitted through the gimbal it must be clearly stated at the time of an enquiry. Other advantages include low forces and the elimination of pressure thrust on adjacent equipment.

Gimbal expansion joints are used either in pairs or in combination with a hinged expansion joint to absorb complex multi-planar movement in a piping system. Furthermore, gimbal expansion joints offer the best possible system for eliminating the effects of thermal expansion, they minimize reaction forces while simultaneously curtailing installation costs because expensive main anchors are unnecessary and only minimal guiding is required.

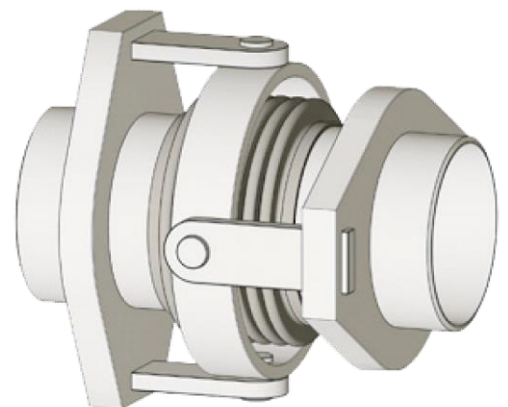

Amniflex B.V.

Abraham van Stolkweg 118
3041 JA, Rotterdam
T: +31(0)10 2982121
E: amniflex@plastiflex.com
www.amniflex.com

BTW nr. NL862140729B01
Bank: KBC Bank NV
KREDNL2XXXX
IBAN NL23 KRED0633024376

K.v.K. Rotterdam nr. 81568053

Al onze aanbiedingen en leveranties geschieden volgens onze algemene leveringsvoorwaarden.



PRESSURE BALANCED EXPANSION JOINT

Pressure balanced expansion joints are designed to absorb axial movement and/or lateral deflection simultaneously restraining the pressure thrust imposed on the system. This is achieved by using tie devices to interconnect the flow bellow with an opposed bellow that is also subjected to line pressure. As the flow bellow is compressed, the tie devices make the balancing bellow extend an equal amount. Since there is no change in the volume of the system, the pressure forces remain in balance. The most common application of the pressure balanced elbow expansion joint is next to a piece of equipment such as a pump or turbine. When substantial amounts of lateral movement are expected, or when the lateral force must be held to a minimum, it is recommended that a pressure balanced universal expansion joint be used with two bellows at the flow end of the expansion joint and a single bellow in the balancing end.



IN-LINE PRESSURE BALANCED EXPANSION JOINT

In-line pressure balanced expansion joints absorb axial movement and/or lateral deflection while restraining the pressure thrust on the system. This is achieved by means of tie devices interconnecting the line bellow with outboard compensating bellows that are also subjected to line pressure. Each bellow set is designed to absorb the axial movement and the line bellow will usually absorb the lateral deflection. Pressure forces that are normally present in a piping system containing bellow expansion joints are not generated when this form of construction is used because the volume changes in the piping system are of equal values.

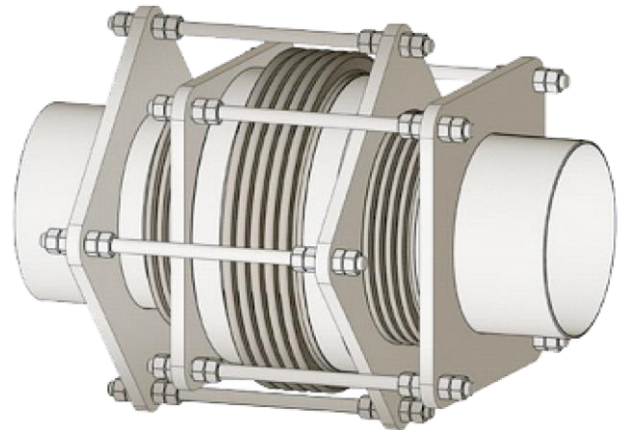

These expansion joints are used where the location of the expansion joint prohibits or makes it very costly to install main anchors.

MANUFACTURING TECHNIQUES

A full range of metal expansion joints are manufactured, customized to the specific needs of the process/chemical industries and the energy/power sectors, providing an optimum balance between flexibility and pressure.

Bellows are manufactured from longitudinally welded cylinders. As standard, multi layered bellows are made by combining and joining several longitudinal cylinders inside each other. Multi layered bellows can also be made from an inside welded cylinder with additional layers wrapped around it.

As the forming methods are highly flexible, we can offer a wide range of bellows shapes configured with almost any number of convolutions and various convolutions heights, pitches etc. Therefore, it's almost always possible to optimize the bellows design with respect to parameters like spring rate etc.

In addition to the standard types found in the tables and data-sheets, the product range covers a full range of individually calculated and manufactured expansion joints.

Amniflex B.V.

Abraham van Stolkweg 118
3041 JA, Rotterdam
T: +31(0)10 2982121
E: amniflex@plastiflex.com
www.amniflex.com

BTW nr. NL862140729B01
Bank: KBC Bank NV
KREDNL2XXXX
IBAN NL23 KRED0633024376

K.v.K. Rotterdam nr. 81568053

Al onze aanbiedingen en leveranties geschieden volgens onze algemene leveringsvoorwaarden.



MANUFACTURING DISCIPLINES

Manufacturing disciplines entail:

- Code calculation according to the standards defined by EJMA, EN, ASME etc.
- Bellows forming
- Welding engineering

Using these disciplines the following manufacturing procedures, are the fundamental basis of the manufacturing procedures:

- 1) dimensional drawing of the expansion joint
- 2) manufacturing specifications of the bellow
- 3) welding specifications (WPS)
- 4) QA specifications

NOMENCLATURE

Absolute diameter

Diameter of the expansion joint. Not to be confused with the nominal diameter, e.g. the absolute diameter of DN 700 can be 711,0 mm.

AN

Type designation for a hinged expansion joint with movements in single or multiple planes. Can be of ANS or ANF type.

AX

Type designation for an united expansion joint designed for axial movement. Can be of AXS, AXF, AXH or DXS type.

Bellows tangent diameter (inside cuff diameter)

Inside diameter of the straight section of a bellow.

Bellow

Convuluted pipe consisting of one or more layers of bellows material.

Bördel flanges

See: Van Stone

Cardan

See: Gimbal

Compression

Contractive movement of the bellow (-)

Control rods

Bars or rods primarily used to distribute the movement between the two bellows of a double lateral expansion joint. Control rods are not designed to restrain bellows pressure thrust.

Convolution height

The height of the convolutions measured from the outside-preferable with a slide gauge.

Convolution pitch

Distance between the convolutions measured from e.g. top-to-top.

Amniflex B.V.

Abraham van Stolkweg 118
3041 JA, Rotterdam
T: +31(0)10 2982121
E: amniflex@plastiflex.com
www.amniflex.com

BTW nr. NL862140729B01
Bank: KBC Bank NV
KREDNL2XXXX
IBAN NL23 KRED0633024376

K.v.K. Rotterdam nr. 81568053

Al onze aanbiedingen en leveranties geschieden volgens onze algemene leveringsvoorwaarden.



Convolutions

The number of convolutions in a complete bellow.
The number is always counted on the outside.

Cover

External protection. Also called outer cover.

Cycle Life

Expected number of full movement cycles calculated according to EJMA. Note: Unless otherwise stated, it is assumed that the movements are not in combination.

Design pressure

Pressure at which expansion joint parameters are calculated.

Drain holes

See: Weep holes

Dye penetrant test

NDT method for detecting surface cracks. A coloured liquid is applied to the weld or surface. Reveals surface cracks.

Expansion joint

A bellow complete with end connections

Fixed flanges

Flanges welded directly to the bellow. Suitable for high pressure and facilitates replacement.

Floating flanges

Loose flanges. (rotatable)

Gimbal unit

Same as a hinge construction except for the fact that the angular movements can be absorbed in two planes.

Hinge

Allows the expansion joint to absorb angular movements in only one plane without transferring reaction forces to the pipe system.

Inner sleeve/liner/baffle

Straight pipe inside of the expansion joint. Protects the bellow from particles in the medium. Can provide a smoother flow at high velocities. Can be installed as single or telescopic construction and may be of loose or fixed type.

Inside diameter

The diameter of free passage measured inside the bellow.

Intermediate pipe

Section between the two bellows in a double bellows construction. Consist of either a separate pipe or, for lower pressure operation, a simple bellow material.

Loose flanges

See: Van Stone

Amniflex B.V.

Abraham van Stolkweg 118
3041 JA, Rotterdam
T: +31(0)10 2982121
E: amniflex@plastiflex.com
www.amniflex.com

BTW nr. NL862140729B01
Bank: KBC Bank NV
KREDNL2XXXX
IBAN NL23 KRED0633024376

K.v.K. Rotterdam nr. 81568053

Al onze aanbiedingen en leveranties geschieden volgens onze algemene leveringsvoorwaarden.



Lap joint flanges

See: Van Stone

Leak test

Test to establish expansion joint tightness.

Limit rods

Typically, these are bars welded to the end connections and used to prevent the expansion joint from axial overstress. Designed to retain full pressure thrust.

Neutral length

The length assumed by an expansion joint when it is released from all restraints. **Nominal diameter (DN)**

Nominal size of the expansion joint.

Nominal pressure

Pressure rating at 20° C. Note that the design pressure for the bellow may vary from the nominal pressure (PN).

Outside diameter

Diameter of the bellow measured from the outside.

Pre-setting

Extending the expansion joint above its neutral length allowing it to absorb larger movements or e.g. operate closer to its neutral length. In this way smaller forces on the pipeline and longer operating spans are imposed. Compression (-), extension (+).

Pressure test

Test of expansion joints pressure integrity. Normally carried out at 1.5x design pressure unless design code or customer requirements specifies otherwise.

Pressure thrust

Force generated from the internal pressure on the active surface of the bellow(s).

Spring rate

The resistance of a bellow to move, measured in N/mm or Nm/°

Stub ends

See: Welding ends

Tie rods

Bars fitted with spherical washers to prevent reaction forces being imposed on the pipe system. Designed to retain full pressure thrust.

Torsion

Angular (rotation) movement around the bellows central axis. Such movements are not allowed and can basically not be absorbed by the bellow/expansion joint. Please contact Amniflex in such cases.

Turnable flanges

Loose flanges

Amniflex B.V.

Abraham van Stolkweg 118
3041 JA, Rotterdam
T: +31(0)10 2982121
E: amniflex@plastiflex.com
www.amniflex.com

BTW nr. NL862140729B01
Bank: KBC Bank NV
KREDNL2XXXX
IBAN NL23 KRED0633024376

K.v.K. Rotterdam nr. 81568053

Al onze aanbiedingen en leveranties geschieden volgens onze algemene leveringsvoorwaarden.



Van Stone ends

Van Stone ends are popular end connections commonly for pressures up to 16 bar. Easy installation. Easy recycling of flanges. More economical than fixed flanges. Less weight. Media does not come into contact with the flange material. (See: End Fittings)

Welding ends

Cheapest and most common type of connection method. Suitable for both high and low pressures.

Welding band

Band, welded to the bellows prior to mounting the end connections.

X-ray

Radioactive examination of welding seams.

All information in this document is without any obligation, specifications subject to change without any notice.

Amniflex B.V.

Abraham van Stolkweg 118
3041 JA, Rotterdam
T: +31(0)10 2982121
E: amniflex@plastiflex.com
www.amniflex.com

BTW nr. NL862140729B01
Bank: KBC Bank NV
KREDNL2XXXX
IBAN NL23 KRED0633024376

K.v.K. Rotterdam nr. 81568053

Al onze aanbiedingen en leveranties geschieden volgens onze algemene leveringsvoorwaarden.

